

Up to 539 lb. Daily Capacity

Ideal For Any Location

The Kold-Draft AKD-125 Automatic Cube Dispenser has an all stainless steel exterior and frame. It is ideal for hospitals, clinics, nursing homes, motels, hotels, resorts and schools.

Push-Button Convenience

The AKD-125 features one-hand, push-button dispensing for ease of operation when filling containers and ice buckets. The auger feed mechanism prevents the waste, spillage and splashing problems caused by gravity dump machines.



Classic GT550 Series Ice Cuber
 on an AKD-125 Dispenser on legs.

Flexible

The AKD-125 Dispenser is designed to easily accommodate the all stainless steel Classic GT550 Series Ice Cuber. This combination gives you up to 539 lbs. of ice production with 125 lbs. of storage capacity.

Kold-Draft's Warranty

Kold-Draft's warranty provides 3 years parts and labor.

Optional Ice Agitation

Kold-Draft's AKD-125 thermostatically-controlled ice agitator can be added to the AKD-125 to keep the ice in the bin in small dispensable pieces. This is recommended when water conditions are not favorable or when the AKD-125 is not used for long periods of time.

Water/Glass Filler Option

AKD-125 dispensers are available with an optional water valve and tapered ice spout for glass filling, for cool clear ice water where you need it.

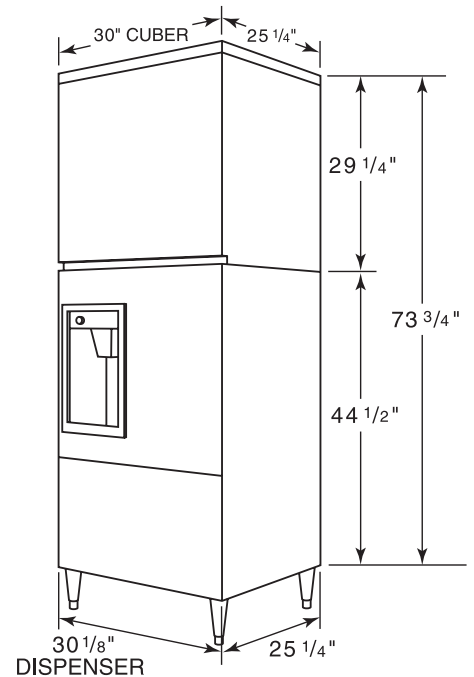

Classic GT550 Series Ice Cuber
 on an AKD-125 Dispenser on legs.
 Stores 125 lbs.* of ice.

*Based on 35 lbs./cu.ft. at 90% of bin volume.

The cold standard in ice!

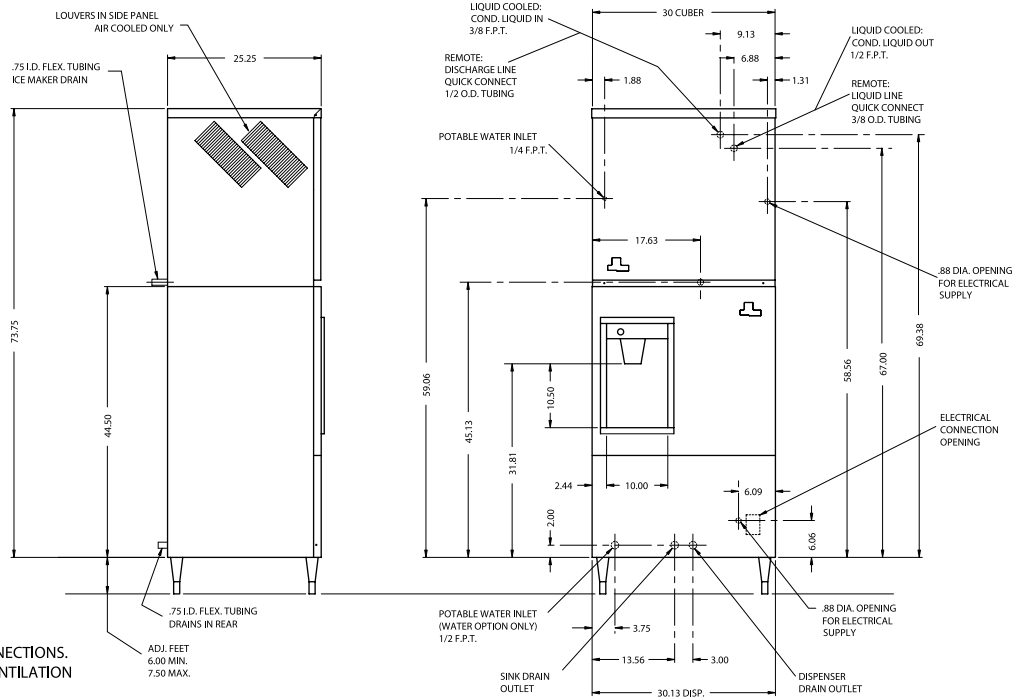

CLEARANCE REQUIREMENTS
 ALLOW CLEARANCE AT BACK FOR CONNECTIONS.
 SEE ICE MAKER SPECIFICATIONS FOR VENTILATION
 CLEARANCE REQUIREMENTS.

General Specifications for AKD-125 Dispenser:

Model	Ice Prod. Per 24 hrs.	Voltage Characteristics	Number of Wires Plus Ground	FLA	HP	Condenser Unit Type	Shipping Weights
AKD-125	–	115-60-1	2	1.9	1/12	–	169 lbs. 77kg
AKD-125-FF	–	208/230-50/60-1	2	1.8	1/12	–	169 lbs. 77kg

Note: Electrical specifications are sized for within 80 ft. or less. All AKD-125's should be wired on a separate circuit.

- Exterior:** All stainless steel standard.
- Interior:** Rotationally-molded polyethylene.
- Plumbing Connections:** Two 3/4" I.D. flex tubing for drains. Bin drain is isolated for sanitation.
- Electrical:** 7/8" diameter opening for conduit fitting. Field connection access on rear panel.
- Motor:** PSC type with automatic thermal overload.
- Storage Capacity:** Approx. 125 lbs. (56.67 kg).
- Insulation:** Polyurethane foam.
- Ice Agitation:** We recommend agitation to keep the ice in small, dispensable pieces when the AKD is not in use for long periods of time. The optional agitation kit is 102116901.
- Mechanism:** Motor-driven auger.
- Loading:** Installation must include Kold-Draft Classic GT Series Ice Cuber.
- Spout:** Universally sized for glass filling and bucket filling.
- Operation:** Dispensing is continuous when push-button is held.
- Water/Glass Filler Option:** Requires a separate potable water line 1/2" F.P.T. connection.

We reserve the right to make product improvements at any time. Specifications and design are subject to change without notice.



1525 E. Lake Road • Erie, PA 16511
 814-453-6761 • 800-840-9577 • Fax: 800-548-9392
 e-mail: info@kold-draft.com • www.kold-draft.com

